

# Transistors

## 2SC1008

### LOW FREQUENCY AMPLIFIER MEDIUM SPEED SWITCHING

- Complement to KSA708
- High Collector-Base Voltage  $V_{CBO} = 80V$
- Collector Current  $I_C = 700mA$
- Collector Dissipation  $P_C = 800mW$

### ABSOLUTE MAXIMUM RATINGS ( $T_a = 25^\circ C$ )

Characteristic	Symbol	Rating	Unit
Collector-Base Voltage	$V_{CBO}$	80	V
Collector-Emitter Voltage	$V_{CEO}$	60	V
Emitter-Base Voltage	$V_{EBO}$	8	V
Collector Current	$I_C$	700	mA
Collector Dissipation	$P_C$	800	mW
Junction Temperature	$T_j$	150	$^\circ C$
Storage Temperature	$T_{stg}$	-55 ~ 150	$^\circ C$

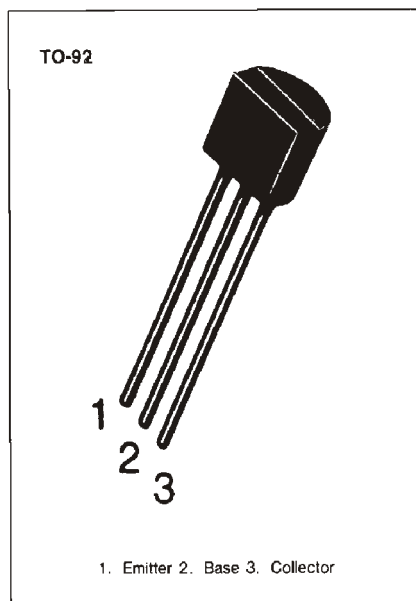

### ELECTRICAL CHARACTERISTICS ( $T_a = 25^\circ C$ )

Characteristic	Symbol	Test Conditions	Min	Typ	Max	Unit
Collector-Base Breakdown Voltage	$BV_{CBO}$	$I_C = 100\mu A, I_E = 0$	80			V
Collector-Emitter Breakdown Voltage	$BV_{CEO}$	$I_C = 10mA, I_B = 0$	60			V
Emitter-Base Breakdown Voltage	$BV_{EBO}$	$I_E = 10\mu A, I_C = 0$	8			V
Collector Cut-off Current	$I_{CBO}$	$V_{CB} = 60V, I_E = 0$			0.1	$\mu A$
Emitter Cut-off Current	$I_{EBO}$	$V_{EB} = 5V, I_C = 0$			0.1	$\mu A$
DC Current Gain	$h_{FE}$	$V_{CE} = 2V, I_C = 50mA$	40		400	
Collector-Emitter Saturation Voltage	$V_{CE(sat)}$	$I_C = 500mA, I_B = 50mA$		0.2	0.4	V
Base-Emitter Saturation Voltage	$V_{BE(sat)}$	$I_C = 500mA, I_B = 50mA$		0.86	1.1	V
Current Gain-Bandwidth Product	$f_T$	$V_{CE} = 10V, I_C = 50mA$	30	50		MHz
Output Capacitance	$C_{ob}$	$V_{CB} = 10V, I_E = 0$ $f = 1MHz$		8		pF

### $h_{FE}$ CLASSIFICATION

Classification	R	O	Y	G
$h_{FE}$	40-80	70-140	120-240	200-400