



SGS-THOMSON
MICROELECTRONICS

BU208/508/508FI
BU208A/508A/508AFI

S G S-THOMSON

30E D
HORIZONTAL TVC DEFLECTION

- HIGH VOLTAGE
- HIGH POWER
- HIGH SWITCHING SPEED
- GOOD STABILITY
- CONSUMER
- POWER SUPPLY
- TV COLOR HORIZONTAL DEFLECTION

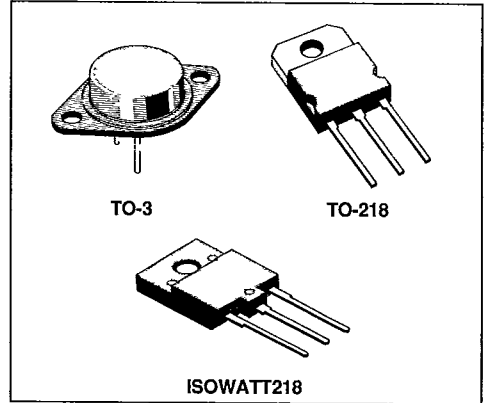

DESCRIPTION

The BU208/A, BU508/A and the BU508FI/AFI are silicon multi-epitaxial mesa NPN transistors.

They are respectively in Jedec TO-3 metal case in TO-218 plastic case and in ISOWATT218 fully isolated package.

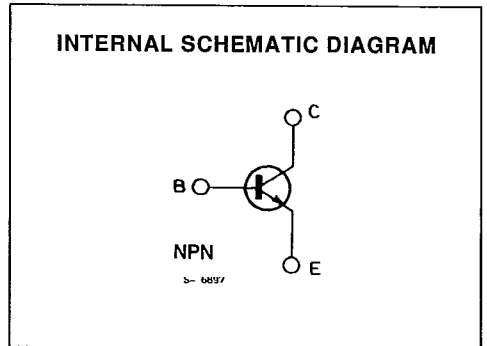

ABSOLUTE MAXIMUM RATINGS

Symbol	Parameter	Value			Unit
		TO-3	TO-218	ISOWATT218	
V _{CEs}	Collector-emitter Voltage (V _{BE} = 0)	1500			V
V _{CEO}	Collector-emitter Voltage (I _B = 0)	700			V
V _{EBO}	Emitter-base Voltage (I _C = 0)	10			V
I _C	Collector Current	8			A
I _{CM}	Collector Peak Current	15			A
P _{tot}	Total Dissipation at T _c = 25°C	150	125	60	W
T _{stg}	Storage Temperature	- 65 to 175	- 65 to 150	- 65 to 150	°C
T _j	Max. Operating Junction Temperature	175	150	150	°C

Figure 1 : Switching Times Test Circuit on Inductive Load.

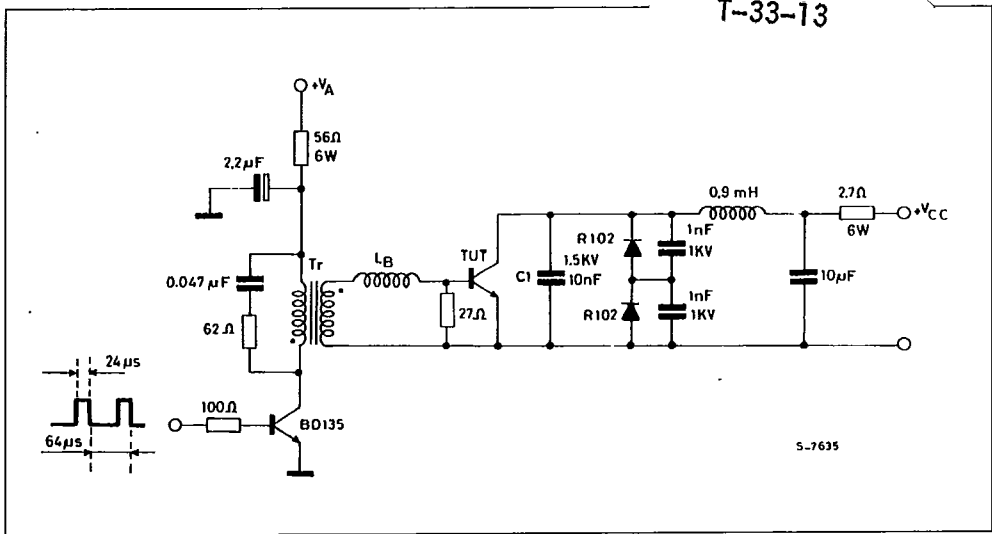

ISOWATT218 PACKAGE CHARACTERISTICS AND APPLICATION

ISOWATT218 is fully isolated to 4000V dc. Its thermal impedance, given in the data sheet, is optimised to give efficient thermal conduction together with excellent electrical isolation. The structure of the case ensures optimum distances between the pins and heatsink. These distances are in agreement with VDE and UL creepage and clearance standards. The ISOWATT218 package eliminates the need for external isolation so reducing fixing hardware.

The package is supplied with leads longer than the standard TO-218 to allow easy mounting on pcbs. Accurate moulding techniques used in manufacture

assures consistent heat spreader-to-heatsink capacitance.

ISOWATT218 thermal performance is equivalent to that of the standard part, mounted with a 0.1 mm mica washer.

The thermally conductive plastic has a higher breakdown rating and is less fragile than mica or plastic sheets.

Power derating for ISOWATT218 packages is determined by :

$$P_D = \frac{T_J - T_C}{R_{th}}$$

THERMAL IMPEDANCE OF ISOWATT218 PACKAGE

Figure 2 illustrates the elements contributing to the thermal resistance of a transistor heatsink assembly, using ISOWATT218 package.

The total thermal resistance $R_{th(tot)}$ is the sum of each of these elements.

The transient thermal impedance, Z_{th} for different pulse durations can be estimated as follows :

1-For a short duration power pulse of less than 1 ms :

$$Z_{th} < R_{thJ-C}$$

2-For an intermediate power pulse of 5ms seconds :

$$Z_{th} = R_{thJ-C}$$

3-For long power pulses of the order of 500ms seconds or greater :

$$Z_{th} = R_{thJ-C} + R_{thC-HS} + R_{thHS-amb}$$

It is often possible to discern these areas on transient thermal impedance curves.

Figure 2.

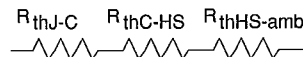

SGS-THOMSON

3OE D

THERMAL DATA

			TO-3	TO-218	ISOWATT218	
$R_{thj-case}$	Thermal Resistance Junction-case	Max	1	1	2.08	°C/W

T-33-13

ELECTRICAL CHARACTERISTICS ($T_{case} = 25^{\circ}C$ unless otherwise specified)

Symbol	Parameter	Test Conditions	Min.	Typ.	Max.	Unit
I_{CES}	Collector Cutoff Current ($V_{BE} = 0$)	$V_{CE} = V_{CES}$ $T_C = 125^{\circ}C$ $V_{CE} = V_{CES}$			1 2	mA mA
I_{EBO}	Emitter Cutoff Current ($I_C = 0$)	$V_{EB} = 5V$			100	μA
$V_{CE0(sus)}^*$	Collector Emitter Sustaining Voltage	$I_C = 100mA$	700			V
V_{EBO}	Emitter-base Voltage ($I_C = 0$)	$I_E = 10mA$	10			V
$V_{CE(sat)}^*$	Collector-emitter Saturation Voltage	$I_C = 4.5A$ $I_B = 2A$ for BU208A/508A/508AFI for BU208/508/508FI			1 5	V V
$V_{BE(sat)}^*$	Base-emitter Saturation Voltage	$I_C = 4.5A$ $I_B = 2A$			1.3	V
f_T	Transition Frequency	$I_C = 0.1A$ $V_{CE} = 5V$ $f = 5MHz$		7		MHz

INDUCTIVE LOAD

Symbol	Parameter	Test Conditions	Min.	Typ.	Max.	Unit.
t_s	Storage Time	$I_C = 4.5A$ $h_{FE} = 2.5$ $V_{CC} = 140V$		7		μs
t_f	Fall Time	$L_C = 0.9mH$ $L_B = 3\mu H$		0.55		μs

* Pulsed : pulse duration = 300 μs , duty cycle = 1.5 %.

Safe Operating Area (TO-3).

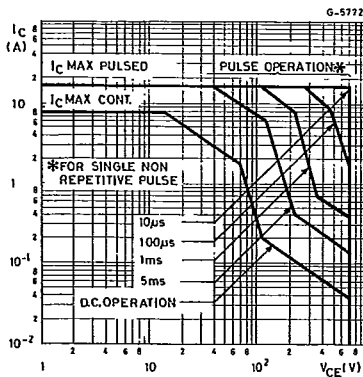

Safe Operating Area (TO-218/ISOWATT218).

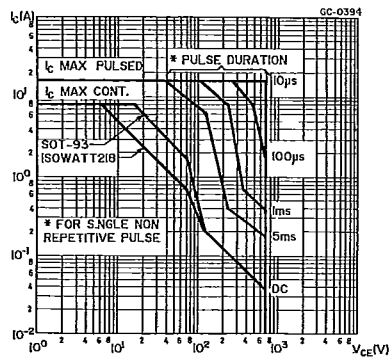

DC Current Gain.

Switching Time Inductive Load.

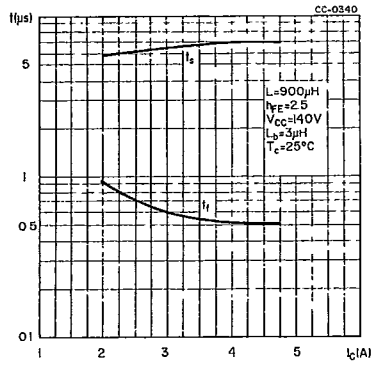
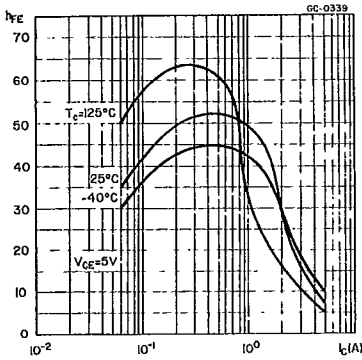

Base-emitter Saturation Voltage.

Collector-emitter Saturation Voltage.

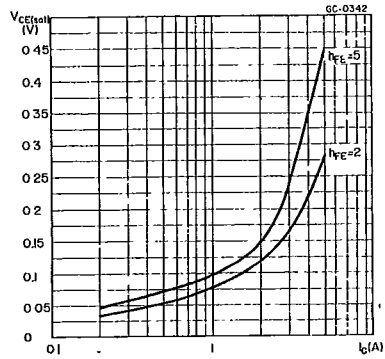
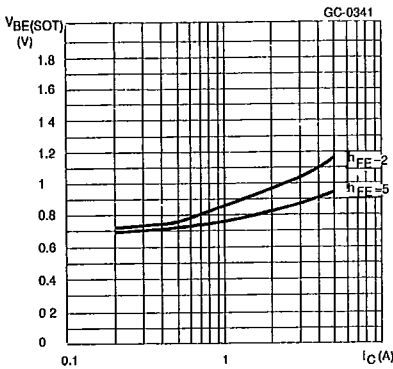

Switching Time Inductive Load.

