

NPN Silicon RF Transistor
Preliminary data

- For highest gain low noise amplifier at 1.8 GHz

Outstanding $G_{ms} = 21$ dB

Noise Figure $F = 0.9$ dB

- Gold metallization for high reliability
- **SIEGET® 45 - Line**

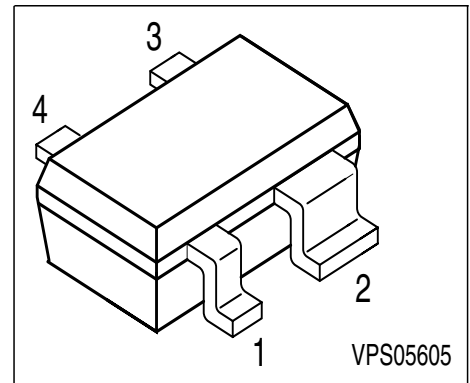

ESD: Electrostatic discharge sensitive device, observe handling precaution!

Type	Marking	Pin Configuration				Package
BFP 540	ATs	1 = B	2 = E	3 = C	4 = E	SOT-343

Maximum Ratings

Parameter	Symbol	Value	Unit
Collector-emitter voltage	V_{CEO}	4.5	V
Collector-base voltage	V_{CBO}	14	
Emitter-base voltage	V_{EBO}	1	
Collector current	I_C	80	mA
Base current	I_B	4	
Total power dissipation, $T_S = 77$ °C ¹⁾	P_{tot}	250	mW
Junction temperature	T_j	150	°C
Ambient temperature	T_A	-65 ... 150	
Storage temperature	T_{stg}	-65 ... 150	

Thermal Resistance

Junction - soldering point	R_{thJS}	≤ 290	K/W
----------------------------	------------	-------	-----

¹⁾ T_S is measured on the emitter lead at the soldering point to the pcb

Electrical Characteristics at $T_A = 25^\circ\text{C}$, unless otherwise specified.

Parameter	Symbol	Values			Unit
		min.	typ.	max.	
DC characteristics					
Collector-emitter breakdown voltage $I_C = 1 \text{ mA}, I_B = 0$	$V_{(BR)CEO}$	4.5	5	6.5	V
Collector-base cutoff current $V_{CB} = 5 \text{ V}, I_E = 0$	I_{CBO}	-	-	200	nA
Emitter-base cutoff current $V_{EB} = 1 \text{ V}, I_C = 0$	I_{EBO}	-	-	70	μA
DC current gain $I_C = 20 \text{ mA}, V_{CE} = 3.5 \text{ V}$	h_{FE}	50	110	200	-
AC Characteristics (verified by random sampling)					
Collector-base capacitance $V_{CB} = 2 \text{ V}, f = 1 \text{ MHz}$	C_{cb}	-	0.14	0.24	pF
Collector-emitter capacitance $V_{CE} = 2 \text{ V}, f = 1 \text{ MHz}$	C_{ce}	-	0.33	-	
Emitter-base capacitance $V_{EB} = 0.5 \text{ V}, f = 1 \text{ MHz}$	C_{eb}	-	0.7	-	
Noise figure $I_C = 5 \text{ mA}, V_{CE} = 2 \text{ V}, Z_S = Z_{Sopt}, f = 1.8 \text{ GHz}$	F	-	0.9	1.3	dB
Power gain, maximum stable ¹⁾ $I_C = 20 \text{ mA}, V_{CE} = 2 \text{ V}, Z_S = Z_{Sopt}, Z_L = Z_{Lopt}, f = 1.8 \text{ GHz}$	G_{ms}	-	21	-	
Insertion power gain $I_C = 20 \text{ mA}, V_{CE} = 2 \text{ V}, f = 1.8 \text{ GHz}, Z_S = Z_L = 50\Omega$	$ S_{21} ^2$	16	18.5	-	
Third order intercept point at output $V_{CE} = 2 \text{ V}, f = 1.8 \text{ GHz}, Z_S = Z_{Sopt}, Z_L = Z_{Lopt}, I_C = 20 \text{ mA}$ $I_C = 7 \text{ mA}$	IP_3	-	24	-	dBm
1dB compression point $V_{CE} = 2 \text{ V}, f = 1.8 \text{ GHz}, Z_S = Z_{Sopt}, Z_L = Z_{Lopt}, I_C = 20 \text{ mA}$ $I_C = 7 \text{ mA}$	P_{-1dB}	-	12	-	
		-	4	-	

$$^1G_{ms} = |S_{21} / S_{12}|$$

Common Emitter S-Parameters

<i>f</i>	<i>S</i> ₁₁		<i>S</i> ₂₁		<i>S</i> ₁₂		<i>S</i> ₂₂	
	MAG	ANG	MAG	ANG	MAG	ANG	MAG	ANG
<i>V</i> _{CE} = 2 V, <i>I</i> _C = 20 mA								
0.01	0.5903	-2.2	42.176	179	0.0008	99.2	0.9567	-0.6
0.1	0.5827	-22.1	40.33	165.1	0.0068	82.2	0.9499	-12.1
0.5	0.4721	-91.8	26.564	121.2	0.0263	62.1	0.6533	-48.1
1	0.4148	-137.4	15.46	96.5	0.0397	56.4	0.3959	-68.2
2	0.413	178	7.897	72.9	0.0646	52.3	0.1912	-90.7
3	0.4426	153	5.257	56.5	0.0892	46.5	0.0982	-117.9
4	0.5064	133.2	3.895	41.6	0.1126	38.1	0.1022	180
5	0.5623	119.5	3.027	28.1	0.1313	29.9	0.1445	147
6	0.5989	109.6	2.471	16.2	0.1525	22.9	0.1764	121.8

*V*_{CE} = 2V, *I*_C = 5 mA

0.01	0.9394	-0.7	7.05	-179.5	0.001	67.1	0.9961	-0.4
0.1	0.937	-7.6	6.922	174.7	0.0087	87.3	0.9976	-3.7
0.5	0.904	-37.9	6.567	152.3	0.0435	70.9	0.9485	-18
1	0.823	-73.1	5.687	128	0.0782	52	0.8283	-33.3
2	0.68	-130	3.983	92.3	0.1073	25.7	0.5958	-52.6
3	0.6308	-170.9	2.913	67	0.1111	12.3	0.4471	-63.7
4	0.6442	156.4	2.251	45.6	0.1076	4.9	0.3504	-78.9
5	0.6757	134.7	1.765	27.5	0.1028	3.7	0.2987	-96.5
6	0.7029	119.7	1.439	12.7	0.1065	7.1	0.2491	-114.9

Common Emitter Noise Parameters

<i>f</i>	<i>F</i> _{min} ¹⁾	<i>G</i> _a ¹⁾	<i>Γ</i> _{opt}		<i>R</i> _N	<i>r</i> _n	<i>F</i> _{50Ω} ²⁾	<i>S</i> ₂₁ ^{2 2)}
	dB	dB	MAG	ANG	Ω	-	dB	dB

*V*_{CE} = 2 V, *I*_C = 5 mA

0.9	0.69	22.7	0.29	34	8	0.16	0.86	21.5
1.8	0.9	17.6	0.13	86	6.5	0.13	0.93	17
2.4	1.06	15.2	0.14	127	6.5	0.13	1.13	14.1
3	1.2	13.6	0.22	163	5.5	0.11	1.31	11.9
4	1.47	11.5	0.33	-153	6	0.12	1.67	9.5
5	1.78	10	0.5	-126	9	0.18	2.17	7.9
6	2.11	8.4	0.55	-107	18	0.36	2.98	5.6

1) Input matched for minimum noise figure, output for maximum gain

2) *Z*_S = *Z*_L = 50Ω

For more and detailed S- and Noise-parameters please contact your local Infineon Technologies distributor or sales office to obtain a Infineon Technologies Application Notes CD-ROM or see Internet: <http://www.infineon.com/products/discrete/index.htm>

SPICE Parameters (Gummel-Poon Model, Berkley-SPICE 2G.6 Syntax) :
Transistor Chip Data

IS =	82.84	aA	BF =	107.5	-	NF =	1	-
VAF =	28.383	V	IKF =	0.48731	A	ISE =	11.15	pA
NE =	3.19	-	BR =	5.5	-	NR =	1	-
VAR =	19.705	V	IKR =	0.02	A	ISC =	19.237	fA
NC =	1.172	-	RB =	1.3	Ω	IRB =	0.72983	mA
RBM =	5.4	Ω	RE =	0.31111		RC =	4	Ω
CJE =	1.8063	fF	VJE =	0.8051	V	MJE =	0.46576	-
TF =	6.76	ps	XTF =	0.4219	-	VTF =	0.23794	V
ITF =	1	mA	PTF =	0	deg	CJC =	234	fF
VJC =	0.81969	V	MJC =	0.30232	-	XCJC =	0.3	-
TR =	2.324	ns	CJS =	0	fF	VJS =	0.75	V
MJS =	0	-	XTB =	0	-	EG =	1.11	eV
XTI =	3	-	FC =	0.73234	-	TNOM	300	K

All parameters are ready to use, no scaling is necessary

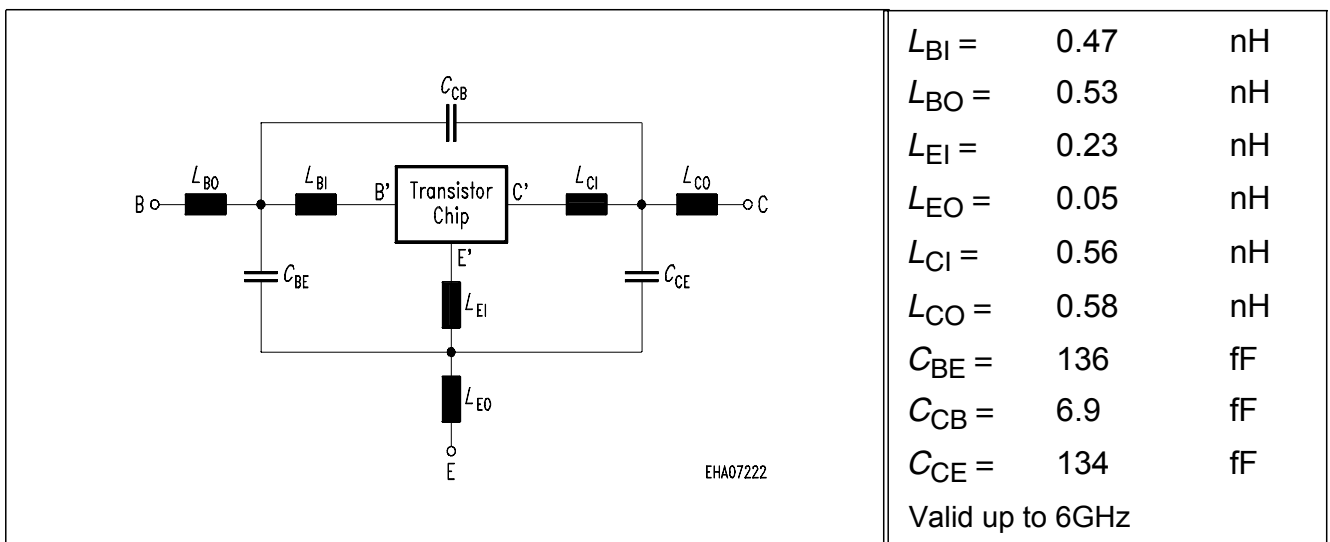
Package Equivalent Circuit:

The SOT-343 package has two emitter leads. To avoid high complexity of the package equivalent circuit, both leads are combined in one electrical connection.

For examples and ready to use parameters please contact your local Infineon Technologies distributor or sales office to obtain a Infineon Technologies CD-ROM or see Internet:
<http://www.infineon.com/products/discrete/index.htm>

For non-linear simulation:

- Use transistor chip parameters in Berkeley SPICE 2G.6 syntax for all simulators.
- Simulation of the package is not necessary for frequencies < 100MHz.
For higher frequencies please add the wiring of the package equivalent circuit around the non-linear transistor.

Advantages of the common emitter configuration:

- Higher gain because of lower emitter inductance.
- Power is dissipated via the grounded emitter leads, because the chip is mounted on the copper emitter leadframe.

Please note, that the broadest lead is the emitter lead.

Total power dissipation $P_{tot} = f(T_A^*, T_S)$

* Package mounted on epoxy

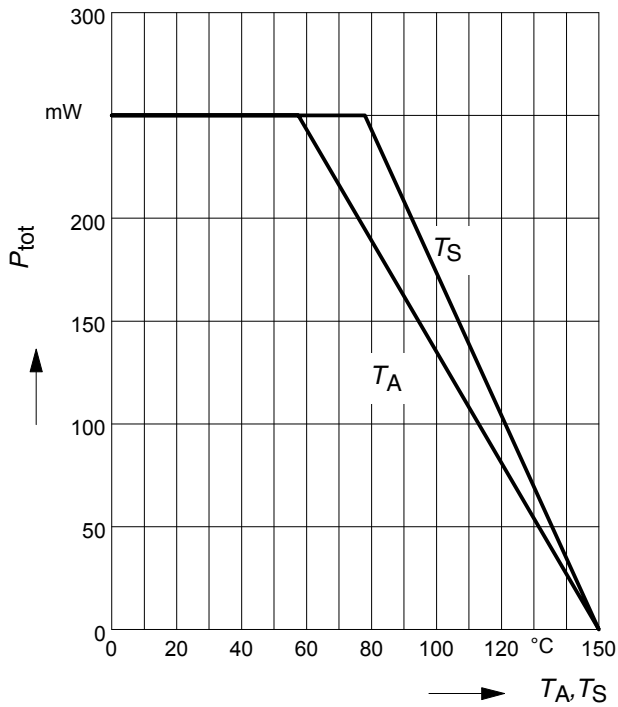

Transition frequency $f_T = f(I_C)$

$f = 1$ GHz

$V_{CE} =$ parameter in V

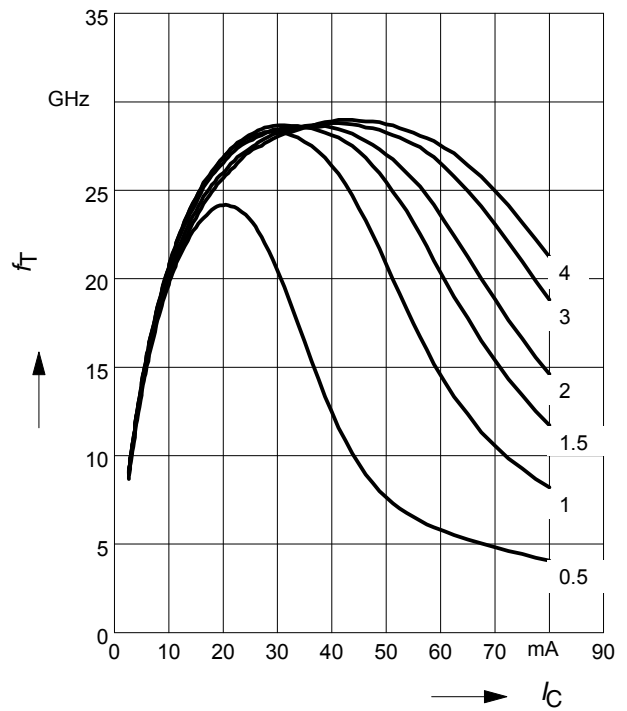

Permissible Pulse Load $R_{thJS} = f(t_p)$

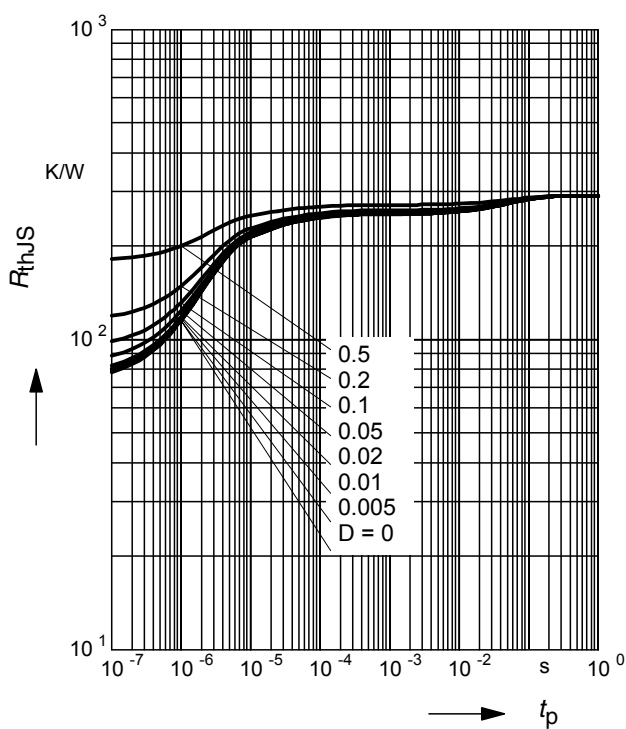

Permissible Pulse Load

$P_{totmax}/P_{totDC} = f(t_p)$

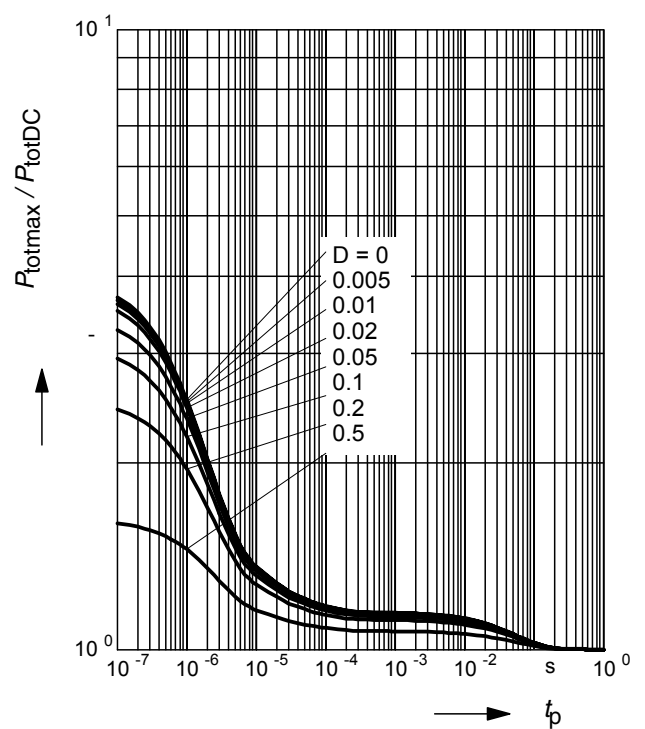

Power gain G_{ma} , G_{ms} , $|S_{21}|^2 = f(f)$

$V_{CE} = 2V$, $I_C = 20\text{ mA}$

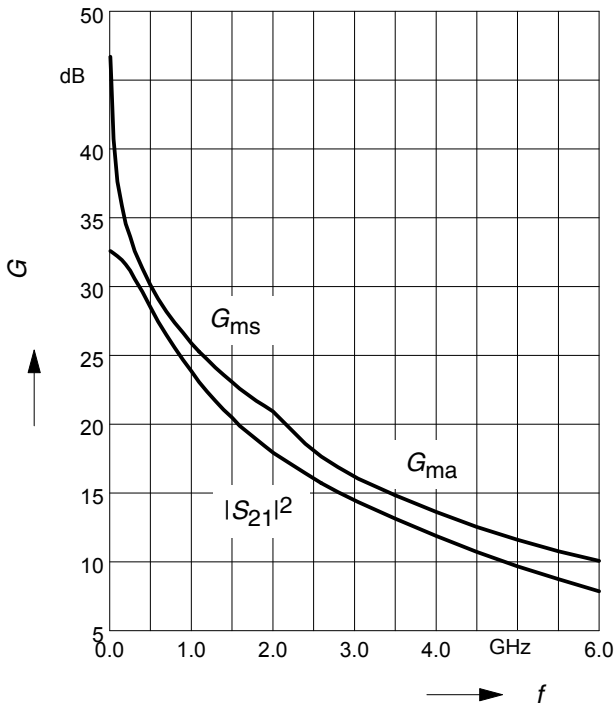

Power gain G_{ma} , $G_{ms} = f(I_C)$

$V_{CE} = 2V$

$f = \text{parameter in GHz}$

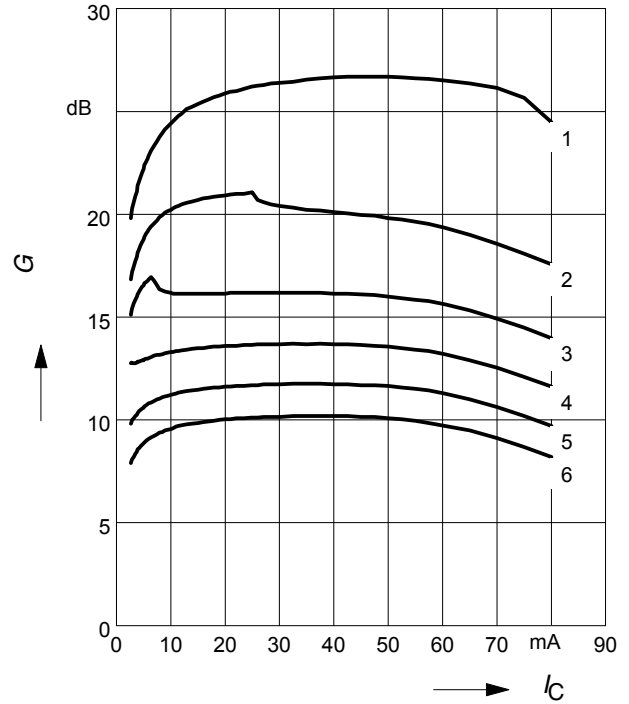

Power gain G_{ma} , $G_{ms} = f(V_{CE})$

$I_C = 20\text{ mA}$

$f = \text{parameter in GHz}$

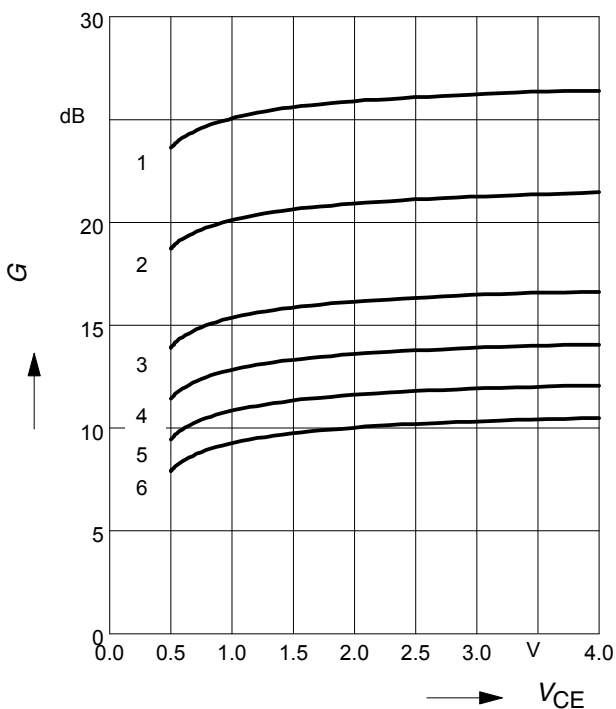

Collector-base capacitance $C_{cb} = f(V_{CB})$

$f = 1\text{ MHz}$

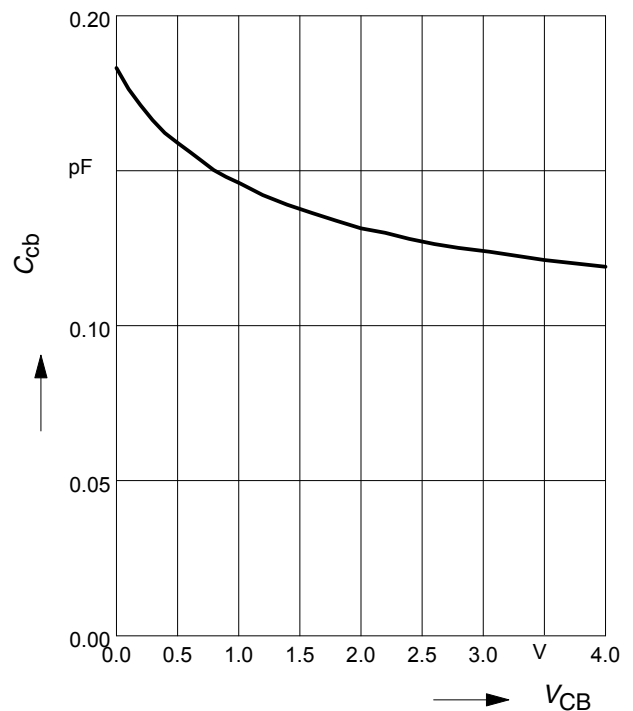

Noise figure $F = f(I_C)$

$V_{CE} = 2\text{ V}$, $Z_S = Z_{Sopt}$

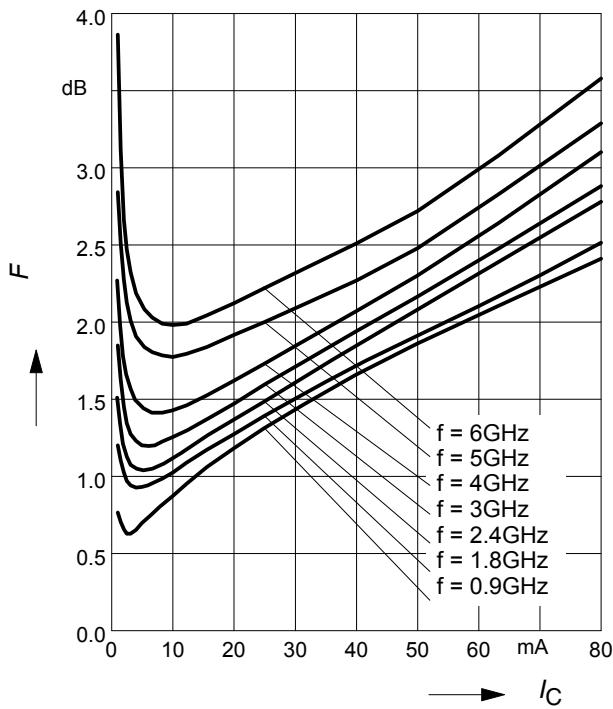

Noise figure $F = f(I_C)$

$V_{CE} = 2\text{ V}$, $f = 1.8\text{ GHz}$

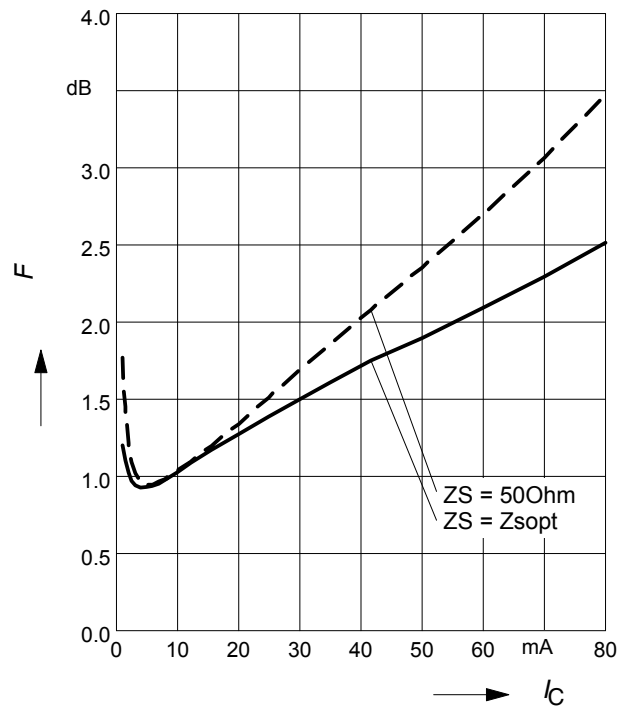

Noise figure $F = f(f)$

$V_{CE} = 2\text{ V}$, $Z_S = Z_{Sopt}$

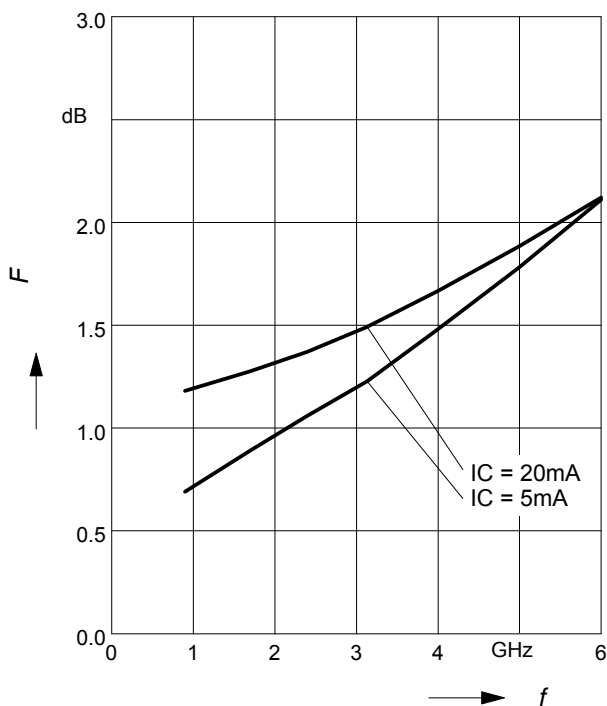

Source impedance for min. noise figure vs. Frequency

$V_{CE} = 2\text{ V}$, $I_C = 5\text{ mA} / 20\text{ mA}$

