

### 30W BTL DUAL AUDIO POWER AMPLIFIER

The thermal resistance  $\theta_{j-c}$  of KIA6221AH package CPP-17 (Compact Power Package 17pin), designed for low thermal resistance, has high efficiency of heat radiation.

The temperature rise of chip can be reduced, and the influence from the degradation of the features due to the temperature rise at the high output can also be reduced.

This stereo audio power IC, designed for car audio use, has two built-in channels to reduce the characteristic difference between L and R channels.

#### FEATURES

- Low Thermal Resistance  
:  $\theta_{j-c}=1.5^{\circ}\text{C}/\text{W}$  (Infinite heat sink)
- High Power  
:  $P_{\text{OUT}}(1)=30\text{W}(\text{Typ.})/\text{Channel}$   
( $V_{\text{CC}}=14.4\text{V}$ ,  $f=1\text{kHz}$ ,  $\text{THD}=10\%$ ,  $R_{\text{L}}=2\Omega$ )  
:  $P_{\text{OUT}}(2)=26\text{W}(\text{Typ.})/\text{Channel}$   
( $V_{\text{CC}}=13.2\text{V}$ ,  $f=1\text{kHz}$ ,  $\text{THD}=10\%$ ,  $R_{\text{L}}=2\Omega$ )  
:  $P_{\text{OUT}}(3)=19\text{W}(\text{Typ.})/\text{Channel}$   
( $V_{\text{CC}}=13.2\text{V}$ ,  $f=1\text{kHz}$ ,  $\text{THD}=10\%$ ,  $R_{\text{L}}=4\Omega$ )
- Low Distortion  
:  $\text{THD}=0.04\%(\text{Typ.})$  ( $V_{\text{CC}}=13.2\text{V}$ ,  $f=1\text{kHz}$ ,  $P_{\text{OUT}}=1\text{W}$ ,  $R_{\text{L}}=4\Omega$ ,  $G_{\text{V}}=50\text{dB}$ )
- Low Noise  
:  $V_{\text{NO}}=0.3\text{mV}_{\text{rms}}(\text{Typ.})$   
( $V_{\text{CC}}=13.2\text{V}$ ,  $R_{\text{L}}=4\Omega$ ,  $G_{\text{V}}=50\text{dB}$ ,  $R_{\text{g}}=0\Omega$ ,  $\text{BW}=20\text{Hz}\sim 20\text{kHz}$ )
- Built-in stand-by function (With ④ pin set at LOW, Power is turned OFF.)  
:  $I_{\text{SB}}=1\mu\text{A}(\text{Typ.})$
- Built-in various protection circuits  
Protection circuits : thermal shut down. over voltage, Out $\rightarrow$ V $_{\text{CC}}$  short.  
Out $\rightarrow$ GND short and OUT-OUT short.
- Operating supply voltage :  $V_{\text{CC}}=9\sim 18\text{V}$

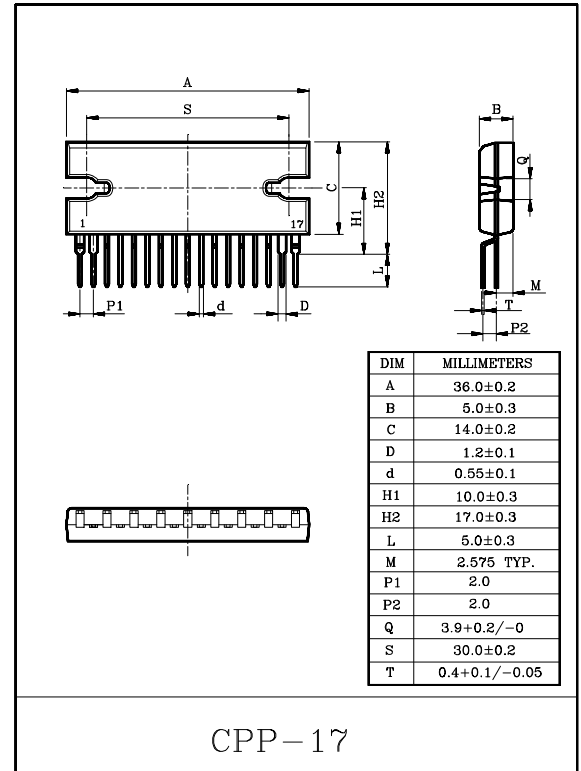

# KIA6221AH

## MAXIMUM RATINGS (Ta=25°C)

CHARACTERISTIC	SYMBOL	RATING	UNIT
Peak Supply Voltage (0.2sec)	V <sub>CC</sub> surge	50	V
DC Supply Voltage	V <sub>CC</sub> DC	25	V
Operating Supply Voltage	V <sub>CC</sub> opr	18	V
Output Current (Peak)	I <sub>O(peak)</sub>	9	A
Power Dissipation	P <sub>D</sub>	50	W
Operating Temperature	T <sub>opr</sub>	-30~85	°C
Storage Temperature	T <sub>stg</sub>	-55~150	°C

## ELECTRICAL CHARACTERISTICS

(Unless otherwise specified, V<sub>CC</sub>=13.2V, R<sub>L</sub>=4Ω, f=1kHz, Ta=25°C)

CHARACTERISTIC	SYMBOL	TEST CIRCUIT	TEST CONDITION	MIN.	TYP.	MAX.	UNIT
Quiescent Supply Current	I <sub>CCQ</sub>	-	V <sub>IN</sub> =0	-	120	250	mA
Output Power	P <sub>OUT</sub> (1)	-	V <sub>CC</sub> =14.4V, THD=10%, R <sub>L</sub> =2Ω	-	30	-	W
	P <sub>OUT</sub> (2)	-	THD=10%, R <sub>L</sub> =2Ω	17	26	-	
	P <sub>OUT</sub> (3)	-	THD=10%	16	19	-	
Total Harmonic Distortion	THD	-	P <sub>OUT</sub> =1W	-	0.04	0.4	%
Voltage Gain	G <sub>V</sub>	-	V <sub>OUT</sub> =0dB	48	50	52	dB
Output Noise Voltage	V <sub>NO</sub>	-	R <sub>g</sub> =0Ω, BW=20Hz~20kHz	-	0.30	0.70	mV <sub>rms</sub>
Ripple Rejection Ratio	R.R	-	f <sub>RIP</sub> =100Hz, R <sub>g</sub> =600Ω, V <sub>RIP</sub> =0dBm	40	54	-	dB
Input Resistance	R <sub>IN</sub>	-	-	-	30	-	kΩ
Output Offset Voltage	V <sub>offset</sub>	-	V <sub>IN</sub> =0	-100	0	100	mV
Current at Stand-by State	I <sub>SB</sub>	-	-	-	100	150	μA
Cross Talk	C.T	-	R <sub>g</sub> =600Ω, V <sub>OUT</sub> =0dBm	-	60	-	dB
① Pin Control Voltage	V <sub>MUTE</sub>	-	Mute→ON (Power→OFF)	-	1.0	2.0	V
④ Pin Control Voltage	V <sub>SB</sub>	-	Stand-by→OFF (Power→ON)	2.5	-	V <sub>CC</sub>	V
Channel Voltage Gain Ratio	ΔG <sub>V</sub>	-	-	-1.0	0	1.0	dB

# KIA6221AH

BLOCK DIAGRAM AND TEST CIRCUIT (Gv=50dB)

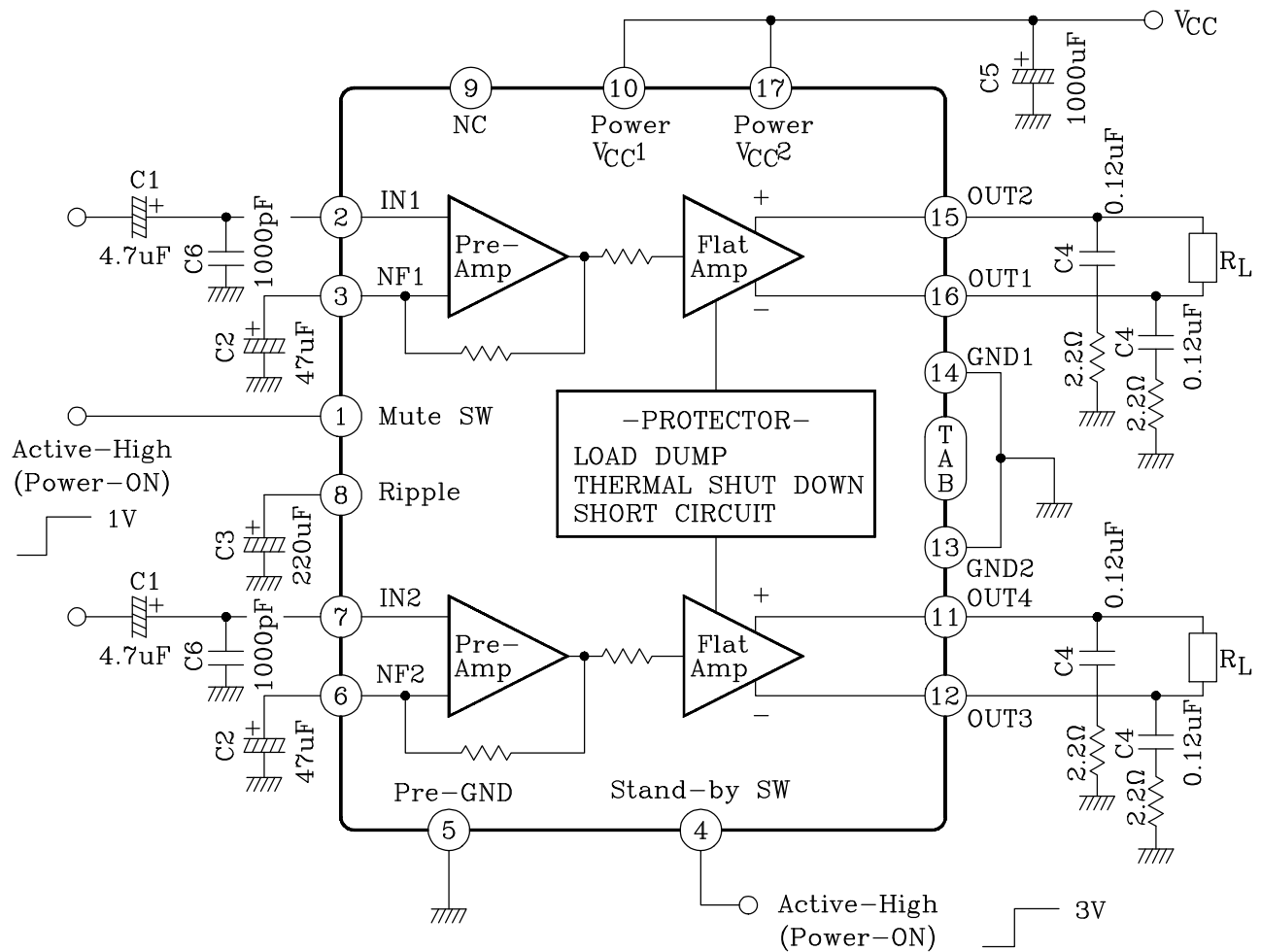

# KIA6221AH

CAUTIONS AND APPLICATION METHOD  
(Description is made only on the single channel.)

## 1. Voltage Gain Adjustment

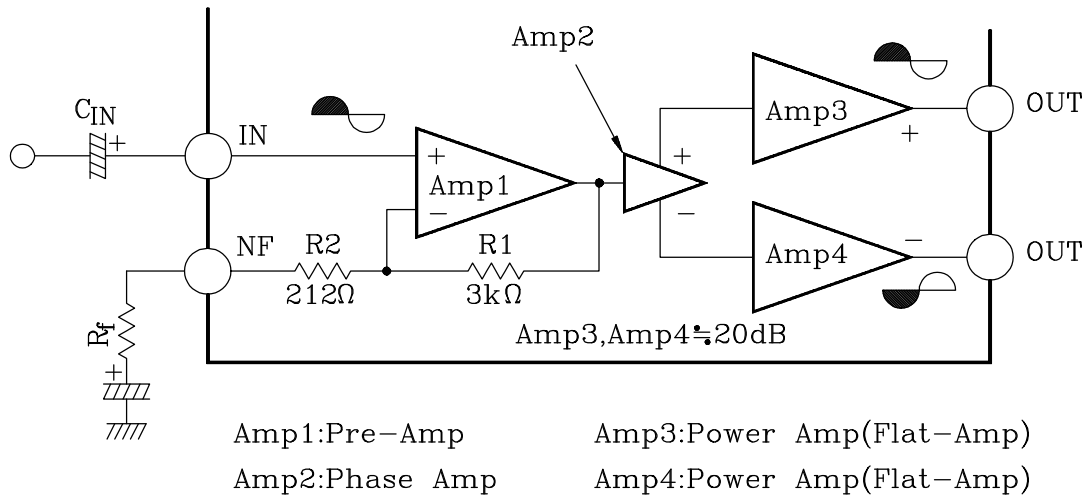

Fig.1

This IC has the amplifier construction as shown in Fig.1. The pre-Amp(Amp 1) is provided to the primary stage, and the input voltage is amplified by the flat Amps. Amp 3 and 4 of each channel through the phase Amp(Amp 2).

Since the input offset is prevented by pre-Amp when  $V_{CC}$  is set to ON, this circuit can remarkably reduce the pop noise.

The total closed loop gain  $G_v$  of this IC can be obtained by expression below when the closed loop voltage gain of Amp 1 is  $G_{v1}$ .

$$G_{v1} = 20 \log \frac{R1 + (Rf + R2)}{Rf + R2} \quad (\text{dB}) \quad \dots \dots \dots (1)$$

The closed loop voltage gain of power Amp, Amp 3 and Amp 4 is fixed at  $G_{v3} \cong G_{v4} = 20\text{dB}$ . Therefore, the total closed circuit voltage gain  $G_v$  is obtained through BTL connection by the expression below.

$$G_v = G_{v1} + G_{v3} + 6(\text{dB}) \quad \dots \dots \dots (2)$$

# KIA6221AH

For example, when  $R_f=0\Omega$ ,  $G_v$  is obtained by the expression (1) and (2) as shown below.

$$G_v \approx 24+20+6=50(\text{dB})$$

The voltage gain is reduced when  $R_f$  is increased. (Fig. 2)

With the voltage gain reduced, since (1) the oscillation stability is reduced, and (2) the pop noise changes when  $V_{CC}$  is set to ON, refer to the items 3 and 4

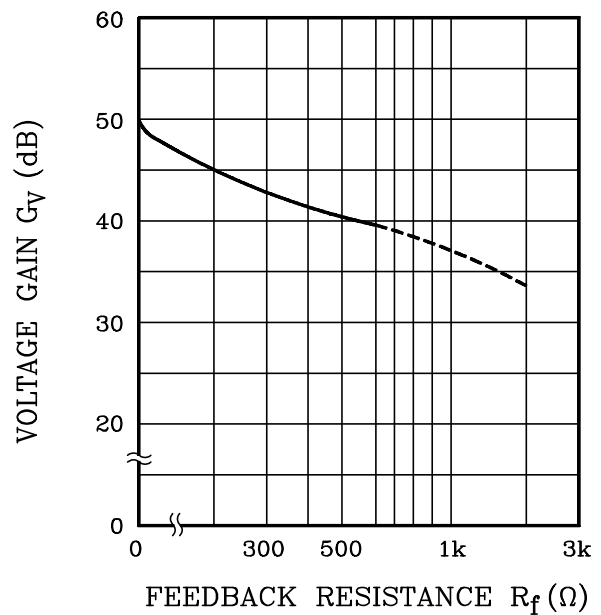

Fig. 2

## 2. Stand-by SW Function

By means of controlling ④ pin (Stand-by terminal) to High and Low, the power supply can be set to ON and OFF.

The threshold voltage of ④ pin is set at about 3V(Typ.), and the power supply current is about 1 $\mu$ A(Typ.) at the stand-by state.

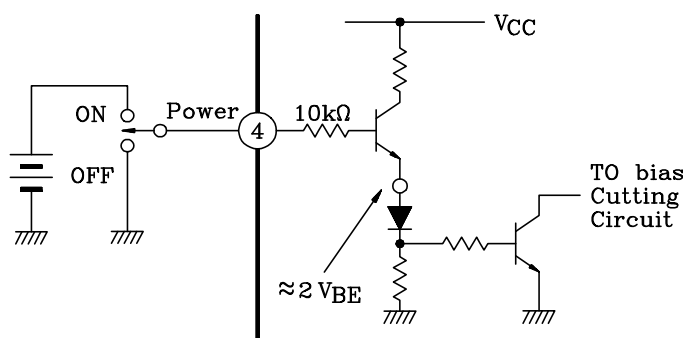

Fig.3 With ④ Pin set to High, Power is turned ON.

# KIA6221AH

④ pin control voltage : V(SB)

Stand-By	Power	V(SB) (V)
ON	OFF	0 ~ 2
OFF	ON	3 ~ V <sub>CC</sub>

Advantage of Stand-by SW

- (1) Since V<sub>CC</sub> can directly be controlled to ON/OFF by the microcomputer, the switching relay can be omitted.
- (2) Since the control current is microscopic, the switching relay of small current capacity is satisfactory of switching.

Large current capacity switch

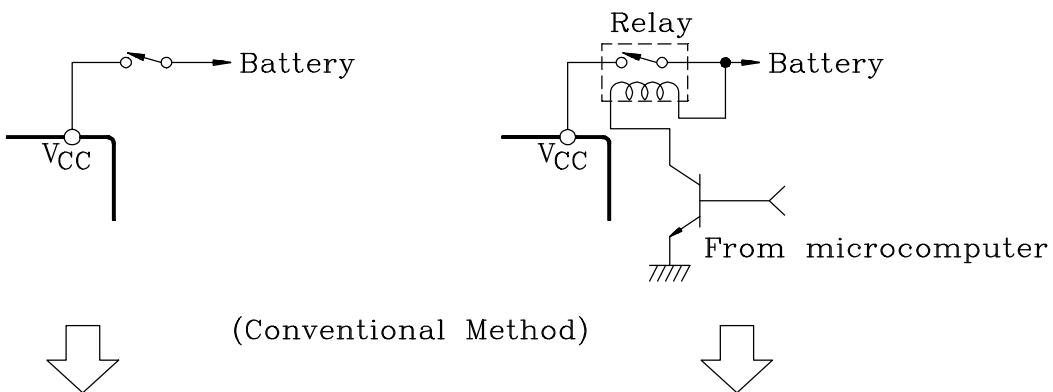

(Conventional Method)

Small current capacity switch

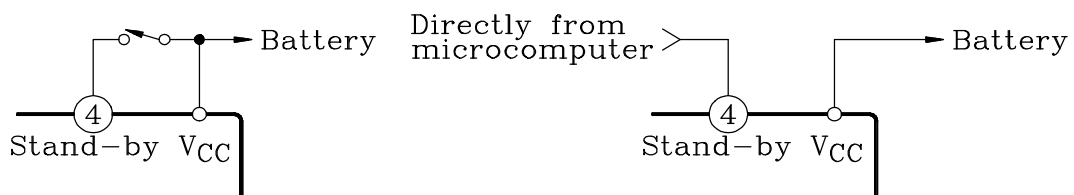

(Stand-by Switch Method)

### 3. Preventive Measure against Oscillation

For preventing the oscillation, it is advisable to use C4, the condenser of polyester film having small characteristic fluctuation of the temperature and the frequency.

The resistance R to be series applied to C4 is effective for phase correction of high frequency, and improves the oscillation allowance.

Since the oscillation allowance is varied according to the causes described below, perform the temperature test to check the oscillation allowance.

- (1) Voltage gain to be used (Gv Setting)
- (2) Capacity value of condenser
- (3) Kind of condenser
- (4) Layout of printed board

In case of its use with the voltage gain Gv reduced or with the feedback amount increased, care must be taken because the phase-inversion is caused by the high frequency resulting in making the oscillation liable generated.

### 4. Input Offset Prevention Circuit At V<sub>CC</sub>→ON

Having Pre-Amp (Amp 1) mounted on the primary stage, this IC contains the circuit for making the Amp 1 input voltage and the NF terminal voltage equipotential. Therefore, the offset voltage produced at the input stage is suppressed to prevent the pop noise at V<sub>CC</sub>→ON. The capacity values of the input and NF condenser (C1 and C2) shall be set according to the gain to be used(Fig 4).

- (Reference)
- (A) At Gv=50dB (Rf=0Ω)  
C1=4.7μF, C2=47μF
  - (B) At Gv=40dB (Rf=470Ω)  
C1=3.3μF, C2=33μF

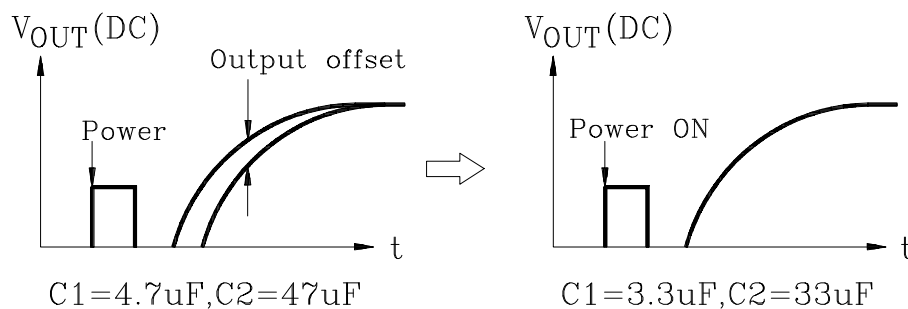

Fig.4

# KIA6221AH

## 5. Muting Function

Through setting ① pin (mute terminal) at about 1V or less, muting becomes possible. The interval circuit of IC is shown in fig.4.

When ① pin is set to LOW, Q1 and Q2 are turned to ON, the charge of the ripple condenser is discharged and the bias is cut. The mute amount of 60dB or over can be obtained.

Since this muting function rapidly discharge the charge of the ripple filter capacitor of ⑧ pin, the pop noise is generated by the DC fluctuation of the bias section.

Therefore, this muting function is not appropriate to the audio muting but it is effective in muting at  $V_{CC} \rightarrow ON$ .

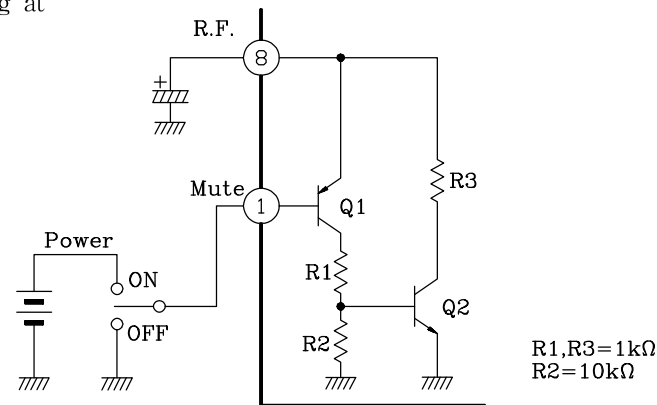

Fig.5 Mute Circuit

## 6. Rapid Ripple Discharging Circuit at the Time of $V_{CC}$ OFF

This circuit is effective in such a mode where the  $V_{CC}$  and the Stand-by terminals become high/low simultaneously ; for instance, for pop noise produced when the power is turned ON/OFF repeatedly by operating the ignition key.

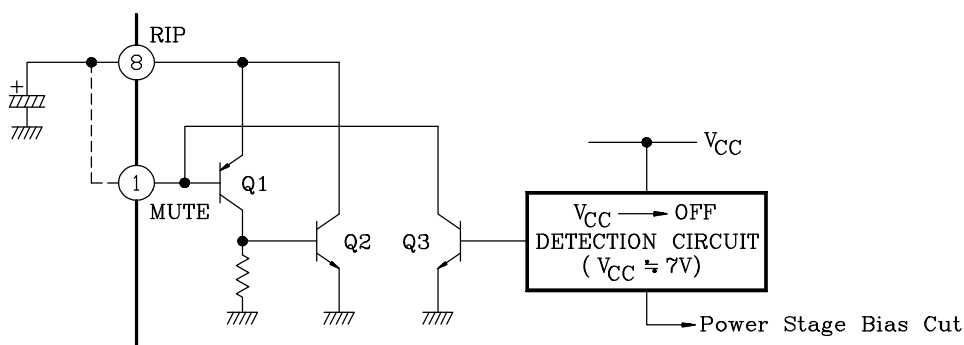

Fig. 6

If  $V_{CC}$  is OFF,  $V_{CC} \approx 7V$  is detected internally on IC and

- (1) The power stage bias circuit is cut, and
- (2) ⑧ pin : Ripple capacitor is rapidly discharged by turning Q3 ON and then Q1 and Q2 ON.



# KIA6221AH

## (Precaution 1)

When the stand-by terminal was put to the low level after the ripple rapid discharging circuit was operated ( $V_{CC} \doteq 7V$ ) at the time when  $V_{CC}$  was turned OFF, a pop noise may be generated. Therefore,  $V_{CC}$  which makes the Stand-by terminal low shall be set at 8V or above so that (1) the Stand-by terminal is put at the low level and (2) the ripple rapid discharging circuit is turned ON when  $V_{CC}$  is turned OFF (in order of (1) and (2)). An example of application is shown in (Fig. 7).

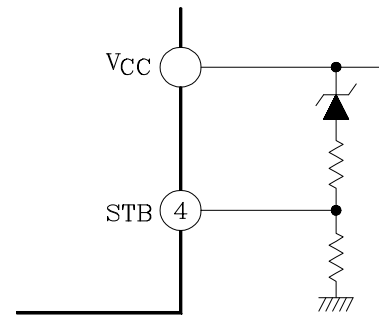

Fig.7

## (Precaution 2)

If the falling time constant of the  $V_{CC}$  line is large (the fall is gentle), the pop noise may become worse.

In this case, it is possible to prevent the pop noise from becoming worse by reducing the capacity of "Ripple rapid Discharging Circuit at the time of  $V_{CC}$  OFF" according to the following steps :

- (a) Short Pin① (Mute Terminal) and Pin⑧ (Ripple Terminal).
- (b) Increase the capacity of ripple capacitor of Pin⑧.

However, it shall be kept in mind that the time for turning the power ON becomes longer as the result of step (b).

# KIA6221AH

## 7. External Part List and Description

SYMBOL	RECOMMEN- DED VALUE	FEATURE	INFLUENCE		REMARKS
			SMALLER THAN RECOMMENDED VALUE	LARGER THAN RECOMMENDED VALUE	
C1	4.7 $\mu$ F	DC Blocking	Related to pop noise at $V_{CC} \rightarrow ON$ .		Related to gain. Refer to item 4.
C2	47 $\mu$ F	Feedback Condenser	Related to pop noise at $V_{CC} \rightarrow ON$ .		
			Determination of low cut-off frequency $C2 = \frac{1}{2\pi f_L \times R_f}$		
C3	220 $\mu$ F	Ripple Reduction	Time constant is small at $V_{CC} \rightarrow ON$ or OFF.	Time constant is large at $V_{CC} \rightarrow ON$ or OFF.	
C4	0.12 $\mu$ F	Oscillation Prevention	Made liable to oscillate.	Oscillation allowance improved.	Refer to item 3.
C5	1000 $\mu$ F	Ripple Filter	For filtering power supply hum and ripple. Large at using AC rectified power supply. Small at using DC power supply.		
C6	1000pF	Oscillation Prevention	Oscillation allowance improved Noise Reduction		Refer to item 3.

# KIA6221AH

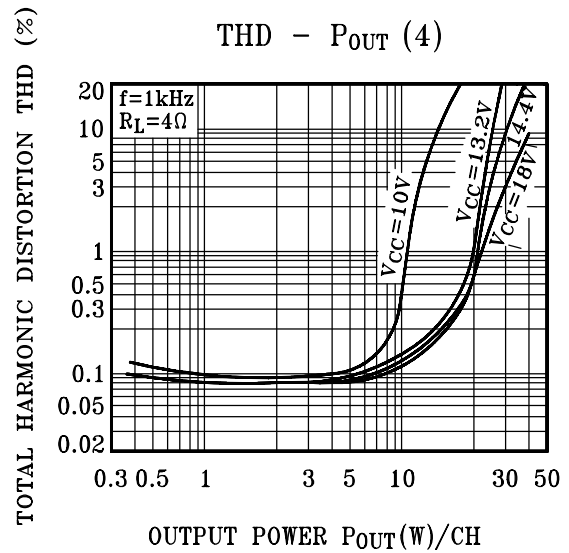
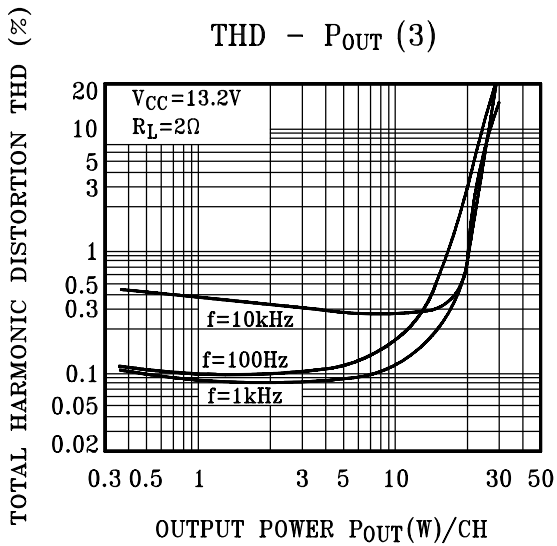
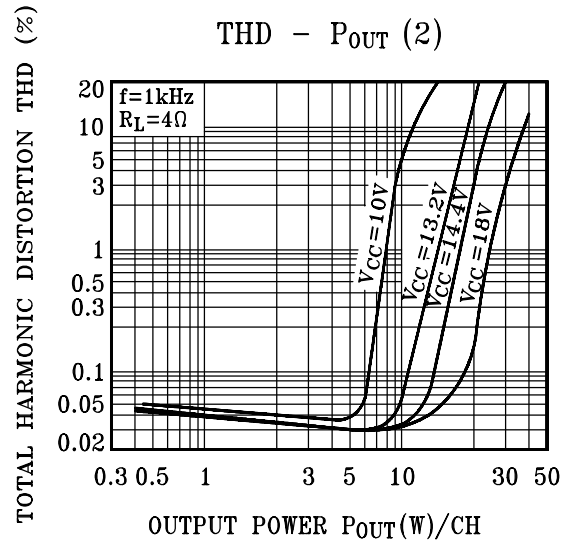
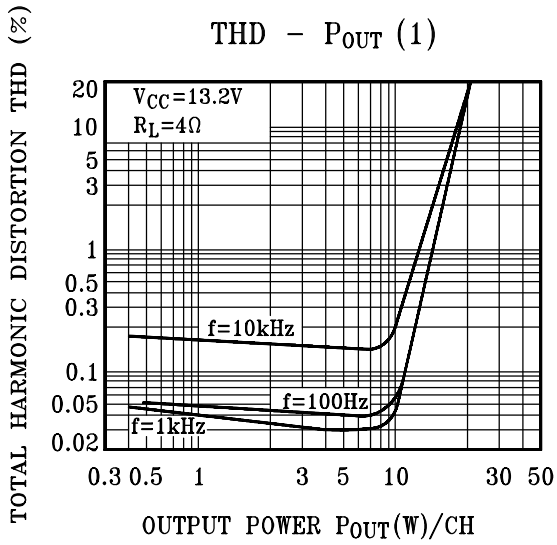

# KIA6221AH

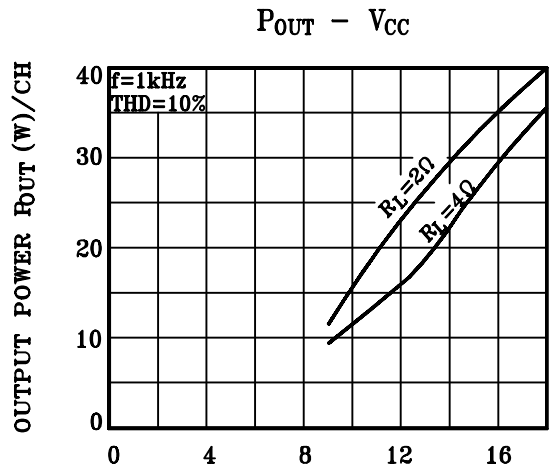
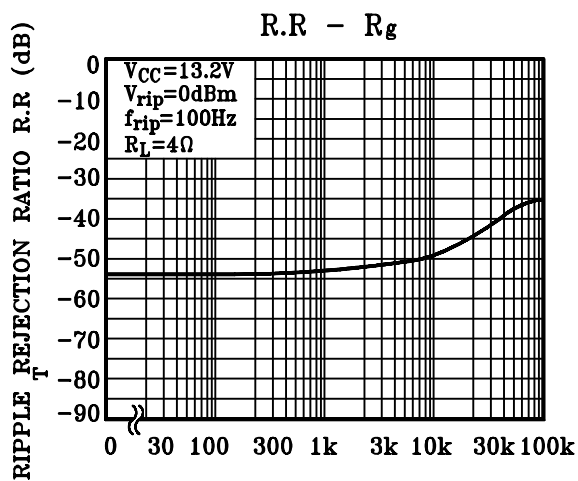
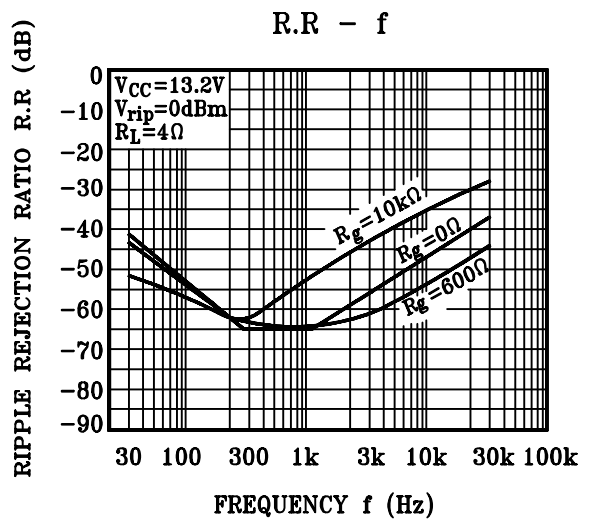
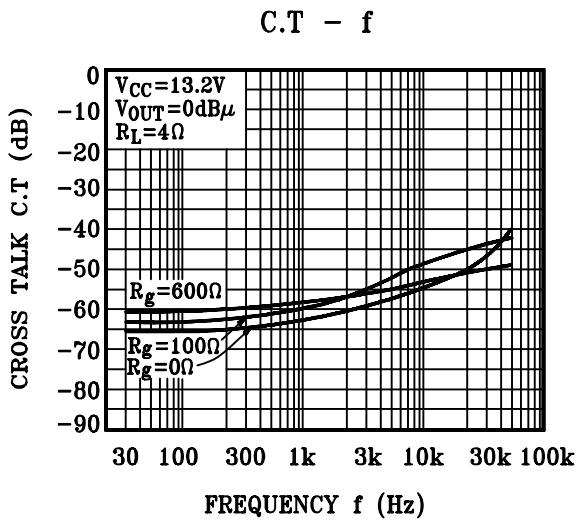
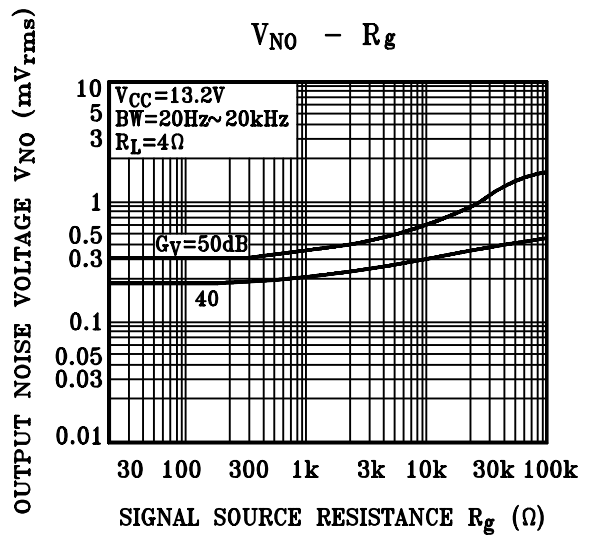
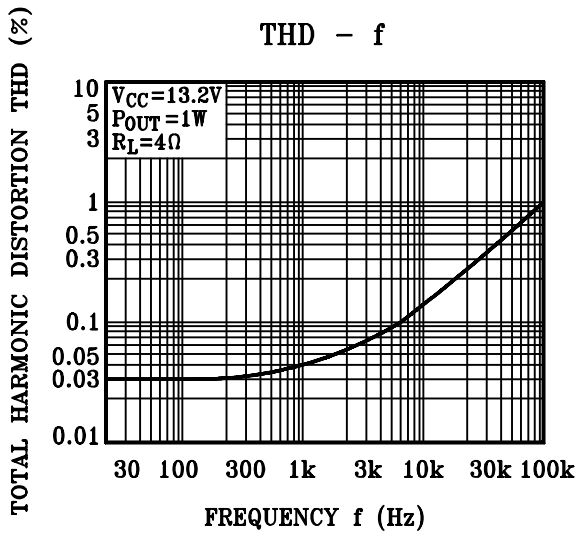

# KIA6221AH

