

Preliminary Information
**Integrated Silicon Pressure Sensor
On-Chip Signal Conditioned,
Temperature Compensated
and Calibrated**

The MPXV5004G series piezoresistive transducer is a state-of-the-art monolithic silicon pressure sensor designed for a wide range of applications, but particularly those employing a microcontroller or microprocessor with A/D inputs. This sensor combines a highly sensitive implanted strain gauge with advanced micromachining techniques, thin-film metallization, and bipolar processing to provide an accurate, high level analog output signal that is proportional to the applied pressure.

Features

- Temperature Compensated over 10° to 60°C
- Ideally Suited for Microprocessor or Microcontroller-Based Systems
- Available in Gauge Configurations

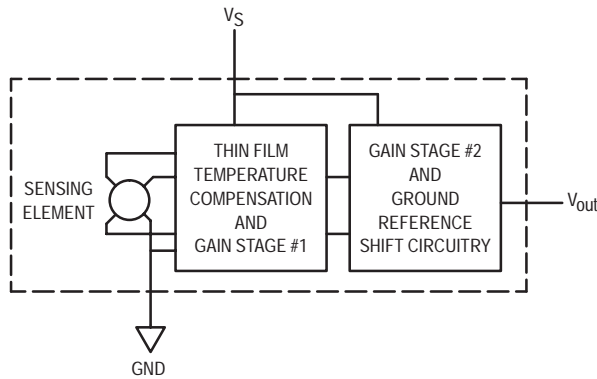

Figure 1. Fully Integrated Pressure Sensor Schematic

MAXIMUM RATINGS(1)

Parametrics	Symbol	Value	Unit
Overpressure(2) (P1 > P2)	P _{max}	10	kPa
Burst Pressure(2) (P1 > P2)	P _{burst}	60	kPa
Storage Temperature	T _{stg}	-30 to +100	°C
Operating Temperature	T _A	0 to +85	°C

1. T_C = 25°C unless otherwise noted.
2. Exposure beyond the specified limits may cause permanent damage or degradation to the device.

**MPXV5004G
SERIES**

**INTEGRATED
PRESSURE SENSOR
0 to 3.92 kPa
(0 to 400 mm H₂O)
1.0 to 4.9 V OUTPUT**

SMALL OUTLINE PACKAGE

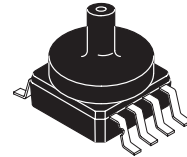

**MPXV5004GC6U
CASE 482A-01**

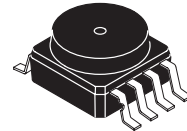

**MPXV5004G6U
CASE 482-01**

PIN NUMBER

1	N/C	5	N/C
2	V _S	6	N/C
3	Gnd	7	N/C
4	V _{out}	8	N/C

NOTE: Pins 1, 5, 6, 7, and 8 are not device connections. Do not connect to external circuitry or ground. Pin 1 is noted by the notch in the Lead.

MPXV5004G SERIES

OPERATING CHARACTERISTICS ($V_S = 5.0$ Vdc, $T_A = 25^\circ\text{C}$ unless otherwise noted, $P_1 > P_2$)

Characteristic	Symbol	Min	Typ	Max	Unit		
Pressure Range	P_{OP}	0	—	3.92 400	kPa mm H ₂ O		
Supply Voltage ⁽¹⁾	V_S	4.75	5.0	5.25	Vdc		
Supply Current	I_S	—	—	10	mAdc		
Span at 306 mm H ₂ O (3 kPa) ⁽²⁾	V_{FSS}	—	3.0	—	V		
Offset ⁽³⁾⁽⁵⁾	V_{off}	0.75	1.00	1.25	V		
Sensitivity	V/P	—	1.0 9.8	—	V/kPa mV/mm H ₂ O		
Accuracy ⁽⁴⁾⁽⁵⁾	0 to 100 mm H ₂ O 100 to 400 mm H ₂ O	(10 to 60°C) (10 to 60°C)	—	—	—	± 1.5 ± 2.5	% V_{FSS} % V_{FSS}

NOTES:

- Device is ratiometric within this specified excitation range.
- Span is defined as the algebraic difference between the output voltage at specified pressure and the output voltage at the minimum rated pressure.
- Offset (V_{off}) is defined as the output voltage at the minimum rated pressure.
- Accuracy (error budget) consists of the following:
 - Linearity: Output deviation from a straight line relationship with pressure over the specified pressure range.
 - Temperature Hysteresis: Output deviation at any temperature within the operating temperature range, after the temperature is cycled to and from the minimum or maximum operating temperature points, with zero differential pressure applied.
 - Pressure Hysteresis: Output deviation at any pressure within the specified range, when this pressure is cycled to and from the minimum or maximum rated pressure, at 25°C.
 - Offset Stability: Output deviation, after 1000 temperature cycles, -30 to 100°C , and 1.5 million pressure cycles, with minimum rated pressure applied.
 - TcSpan: Output deviation over the temperature range of 10 to 60°C , relative to 25°C .
 - TcOffset: Output deviation with minimum rated pressure applied, over the temperature range of 10 to 60°C , relative to 25°C .
 - Variation from Nominal: The variation from nominal values, for Offset or Full Scale Span, as a percent of V_{FSS} , at 25°C .
- Auto Zero at Factory Installation: Due to the sensitivity of the MPXV5004G, external mechanical stresses and mounting position can affect the zero pressure output reading. Autozeroing is defined as storing the zero pressure output reading and subtracting this from the device's output during normal operations. Reference AN1636 for specific information. The specified accuracy assumes a maximum temperature change of $\pm 5^\circ\text{C}$ between autozero and measurement.

ON-CHIP TEMPERATURE COMPENSATION, CALIBRATION AND SIGNAL CONDITIONING

The performance over temperature is achieved by integrating the shear-stress strain gauge, temperature compensation, calibration and signal conditioning circuitry onto a single monolithic chip.

Figure 2 illustrates the gauge configuration in the basic chip carrier (Case 473). A fluorosilicone gel isolates the die surface and wire bonds from the environment, while allowing the pressure signal to be transmitted to the silicon diaphragm.

The MPXV5004G series sensor operating characteristics are based on use of dry air as pressure media. Media, other than dry air, may have adverse effects on sensor performance

and long-term reliability. Internal reliability and qualification test for dry air, and other media, are available from the factory. Contact the factory for information regarding media tolerance in your application.

Figure 3 shows a typical decoupling circuit for interfacing the output of the MPXV5004G to the A/D microprocessor. Proper decoupling of the power supply is recommended.

Figure 4 shows the sensor output signal relative to pressure input. Typical, minimum and maximum output curves are shown for operation over 10°C to 60°C. (Device output may be nonlinear outside of the rated pressure range.)

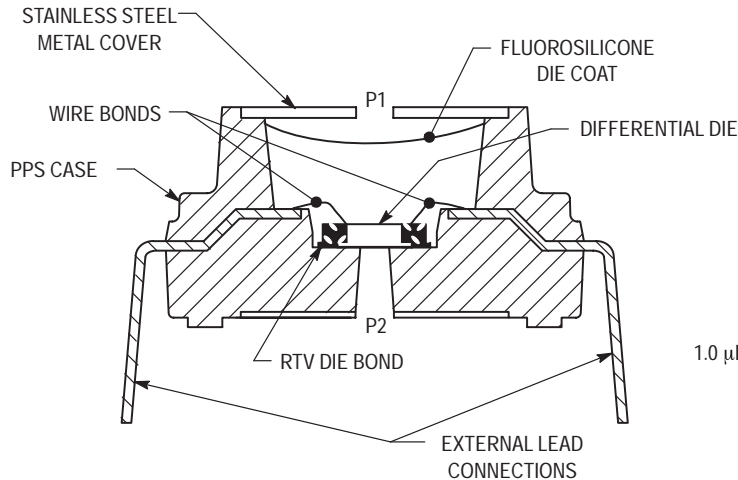

Figure 2. Cross-Sectional Diagram (Not to Scale)

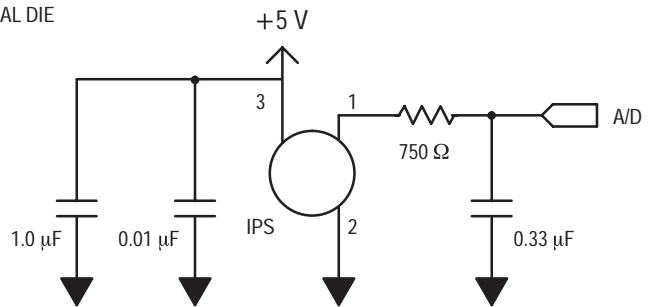

Figure 3. Recommended power supply decoupling and output filtering. Please refer to Application Note AN1646.

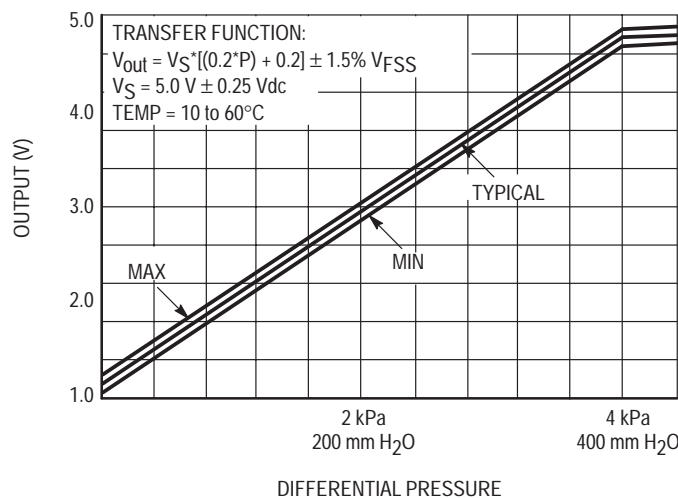

Figure 4. Output versus Pressure Differential

(See Note 5 in Operating Characteristics)

MPXV5004G SERIES

PRESSURE (P1)/VACUUM (P2) SIDE IDENTIFICATION TABLE

Motorola designates the two sides of the pressure sensor as the Pressure (P1) side and the Vacuum (P2) side. The Pressure (P1) side is the side containing silicone gel which isolates the die from the environment. The Motorola pressure

sensor is designed to operate with positive differential pressure applied, $P1 > P2$.

The Pressure (P1) side may be identified by using the table below:

Part Number	Case Type	Pressure (P1) Side Identifier
MPXV5004GC6U	482A-01	Side with Port Attached
MPXV5004G6U	482-01	Stainless Steel Cap

ORDERING INFORMATION

MPXV5004G series pressure sensors are available in two gauge configurations. Devices are available in the basic element package or with a pressure port.

Device Type	Case No.	Packing Options	Device Marking
MPXV5004G6U	482-01	Rails	MPXV5004G
MPXV5004G6T1	482-01	Tape and Reel	MPXV5004G
MPXV5004GC6U	482A-01	Rails	MPXV5004G
MPXV5004GC6T1	482A-01	Tape and Reel	MPXV5004G

INFORMATION FOR USING THE SMALL OUTLINE PACKAGE (CASE 482)

MINIMUM RECOMMENDED FOOTPRINT FOR SURFACE MOUNTED APPLICATIONS

Surface mount board layout is a critical portion of the total design. The footprint for the surface mount packages must be the correct size to ensure proper solder connection interface between the board and the package. With the correct

footprint, the packages will self align when subjected to a solder reflow process. It is always recommended to design boards with a solder mask layer to avoid bridging and shorting between solder pads.

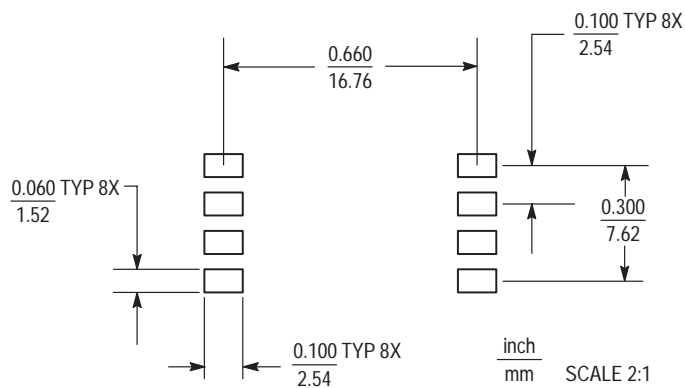
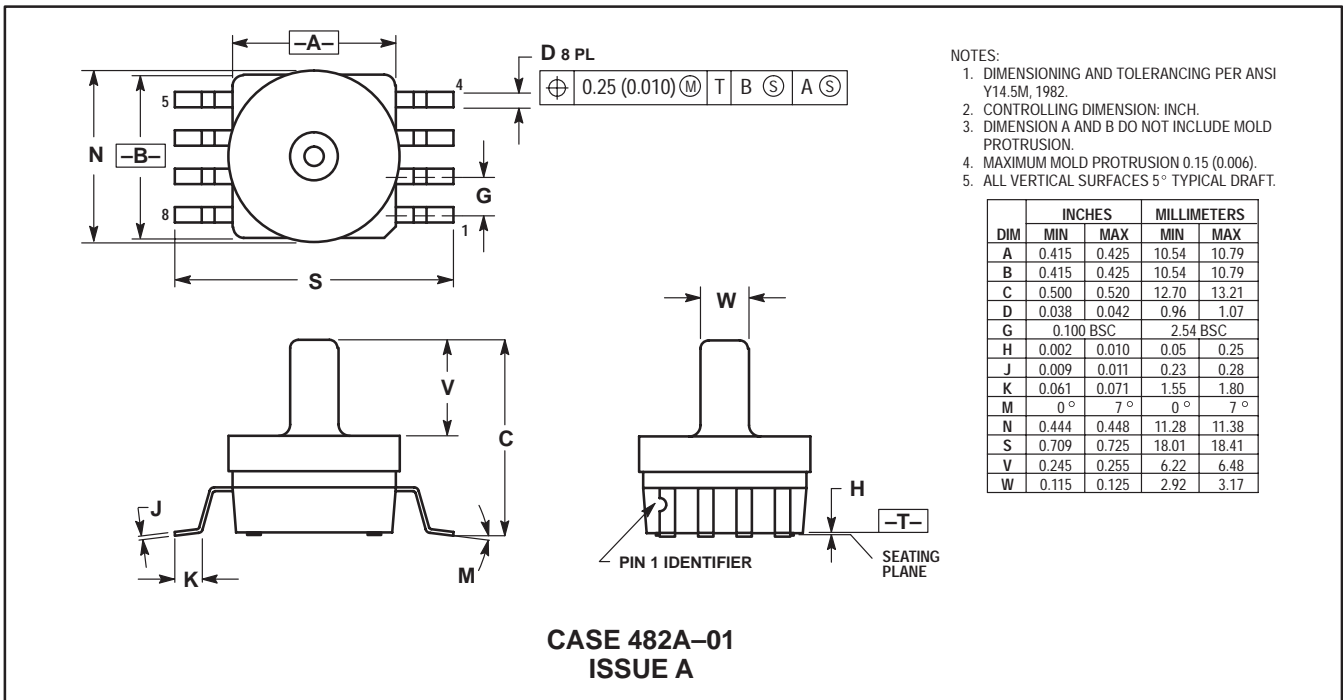
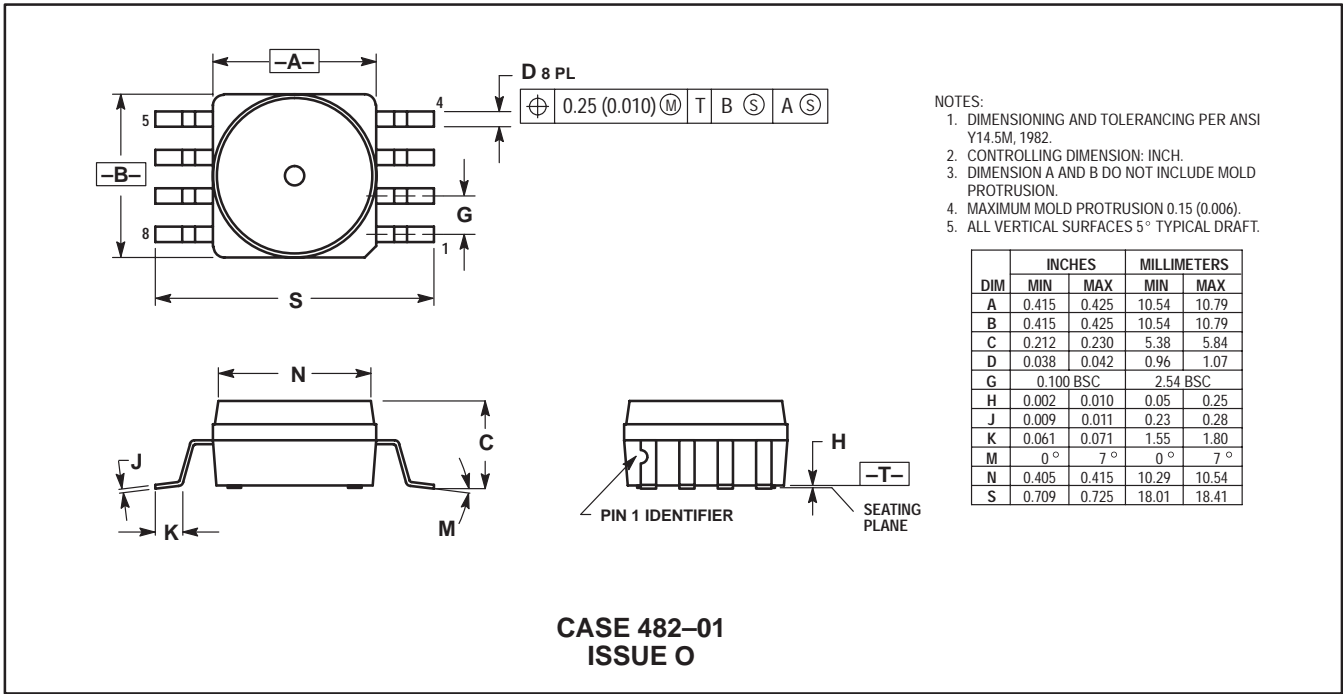

Figure 5. SOP Footprint (Case 482)

SMALL OUTLINE PACKAGE DIMENSIONS



NOTES

NOTES

MPXV5004G SERIES

Mfax is a trademark of Motorola, Inc.

Motorola reserves the right to make changes without further notice to any products herein. Motorola makes no warranty, representation or guarantee regarding the suitability of its products for any particular purpose, nor does Motorola assume any liability arising out of the application or use of any product or circuit, and specifically disclaims any and all liability, including without limitation consequential or incidental damages. "Typical" parameters which may be provided in Motorola data sheets and/or specifications can and do vary in different applications and actual performance may vary over time. All operating parameters, including "Typicals" must be validated for each customer application by customer's technical experts. Motorola does not convey any license under its patent rights nor the rights of others. Motorola products are not designed, intended, or authorized for use as components in systems intended for surgical implant into the body, or other applications intended to support or sustain life, or for any other application in which the failure of the Motorola product could create a situation where personal injury or death may occur. Should Buyer purchase or use Motorola products for any such unintended or unauthorized application, Buyer shall indemnify and hold Motorola and its officers, employees, subsidiaries, affiliates, and distributors harmless against all claims, costs, damages, and expenses, and reasonable attorney fees arising out of, directly or indirectly, any claim of personal injury or death associated with such unintended or unauthorized use, even if such claim alleges that Motorola was negligent regarding the design or manufacture of the part. Motorola and  are registered trademarks of Motorola, Inc. Motorola, Inc. is an Equal Opportunity/Affirmative Action Employer.

How to reach us:

USA/EUROPE/Locations Not Listed: Motorola Literature Distribution; P.O. Box 5405, Denver, Colorado 80217.
1-303-675-2140 or 1-800-441-2447

JAPAN: Motorola Japan Ltd.; SPS, Technical Information Center, 3-20-1, Minami-Azabu, Minato-ku, Tokyo 106-8573 Japan.
81-3-3440-3569

ASIA/PACIFIC: Motorola Semiconductors H.K. Ltd.; Silicon Harbour Centre, 2 Dai King Street, Tai Po Industrial Estate, Tai Po, N.T., Hong Kong. 852-26668334

Customer Focus Center: 1-800-521-6274

Mfax™: RMFAX0@email.sps.mot.com – TOUCHTONE 1-602-244-6609
Motorola Fax Back System – US & Canada ONLY 1-800-774-1848
– http://sps.motorola.com/mfax/

HOME PAGE: <http://motorola.com/sps/>

